



深圳市华源显控技术股份有限公司
Shenzhen HuaYuan display control technique.,Ltd
深圳市芯云显控技术有限公司
Shenzhen Chiloud display control Co.,Ltd

PRODUCT SPECIFICATIONS

Preliminary Specification

Module No: VISLCD-024HYC118C01

PRODUCT TYPE: TFT MODULE

VERSION: V0

Huayuan:

APPROVED BY	CHECKED BY	DESIGNED BY
		Jiang

Customer:

APPROVED BY	TESTED BY	INSPECTION RESULT



Table of Contents

Table of Contents	2
Record of Revision	3
1 General Specifications.....	4
2 Input/Output Terminals.....	5
3 Absolute Maximum Ratings.....	6
4 Electrical Characteristics	7
5 Timing Chart.....	9
6 Optical Characteristics	15
7 Environmental / Reliability Test.....	18
8 Mechanical Drawing.....	19
9 Precautions for Use of LCD Modules.....	20

Hunan Huayuan display technology CO.,LTD



1 General Specifications

	Feature	Spec
Display Spec.	Size	2.4"
	Resolution	240(RGB)x320
	Technology Type	a-si TFT
	Pixel Configuration	RGB Vertical Stripe
	Pixel pitch(mm)	0.153 x 0.153
	Display Mode	CT,NW
	Surface Treatment	Clear Type
	Viewing Direction	12 o'clock
	Gray Scale Inversion Direction	6 o'clock
Mechanical Characteristics	LCM (W x H x D) (mm)	42.72x60.26x2.2
	Active Area(mm)	36.72x48.96
	With /Without TSP	With RTP
	Matching Connection Type	18pin-0.8mm
	LED Numbers	4
	Weight (g)	12
Electrical Characteristics	Interface	SPI 4 WIRE
	Color Depth	262K
	Driver IC	ST7789

Note 1: Viewing direction for best image quality is different from TFT definition. There is a 180 degree shift.

Note 2: Requirements on Environmental Protection: Q/S0002

Note 3: LCM weight tolerance: $\pm 5\%$



2 Input/Output Terminals

Matched connector: 18pin-0.8mm

PIN No.	Symbol	Description
1	GND	Ground (接地脚)
2	RESET	LCM Reset pin Signal is active low. (屏复位脚, 低电平复位)
3	SCL	This pin is used serial interface clock in 4-wire 8-bit serial data interface. (4线串口的时钟信号) If not used, this pin should be connected to IOVCC or GND. (不用时接IOVCC或者接地)
4	D/C	- 4-line system (D/CX): Serves as command or parameter select. Fix to IOVCC level when not in use. (4线串口的寄存器/数据选择, 不用时接 IOVCC)
5	CS	Chip select pin ("Low" enable) (屏驱动芯片片选脚, 低电平有效)
6	SDA	Serial input signal. The data is applied on the rising edge of the SCL signal. If not used, fix this pin at IOVCC or GND (串口数据输入信号, 不用时接 IOVCC 或者接地)
7	SDO	Serial output signal. The data is outputted on the falling edge of the SCL signal. If not used, open this pin (串口数据输出信号, 不用时空悬)
8	GND	Ground (接地脚)
9	VCC	Power supply for LCM (2.8V-3.3V) (屏供电脚)
10	LEDA	Anode of Backlight (3.0V-3.4V Typical:3.2V) (背光正极供电脚, 电压范围:3.0-3.4V, 典型值:3.2V)
11	LEDK1	Cathode of Backlight (背光负极供电脚)
12	LEDK2	Cathode of Backlight (背光负极供电脚)
13	LEDK3	Cathode of Backlight (背光负极供电脚)
14	LEDK4	Cathode of Backlight (背光负极供电脚)
15	XL	Touch panel control pin (触摸屏控制脚)
16	YU	Touch panel control pin (触摸屏控制脚)
17	XR	Touch panel control pin (触摸屏控制脚)
18	YD	Touch panel control pin (触摸屏控制脚)

Note1,, Please add the FPC connector type and matched one if necessary .



3 Absolute Maximum Ratings

GND=0V

Item	Symbol	MIN	MAX	Unit	Remark
Power Voltage	VCC	-0.3	4.6	V	Note1
Input voltage	V _{IN}	-0.3	4.6	V	
Operating Temperature	Top	-20	70	°C	
Storage Temperature	Tst	-30	80	°C	
Relative Humidity Note2	RH	--	““95	%	Ta““40°C
		--	““85	%	40°C<Ta““50°C
		--	““55	%	50°C<Ta““60°C
		--	““36	%	60°C<Ta““70°C
		--	““24	%	70°C<Ta““80°C
Absolute Humidity	AH	--	““70	g/m ³	Ta>70°C

Table 3 Absolute Maximum Ratings

Note1: Input voltage include R0~R5, G0~G5, B0~B5, Dotclk, Hsync, Vsync, Enable, R/L, U/D.

Note2: Ta means the ambient temperature.

It is necessary to limit the relative humidity to the specified temperature range.

Condensation on the module is not allowed.



4 Electrical Characteristics

4.1 LCD Module

GND=0V, Ta=25?

Item	Symbol	MIN	TYP	MAX	Unit	Remark
Logic Supply Voltage	IOVCC	2.5	2.8	3.3+/-10%	V	
Analog Supply Voltage	VCC	2.5	2.8	3.3+/-10%	V	
Input Signal Voltage	High Level	0.7 IOVCC	-	IOVCC	V	
	Low Level	-	-	0.3 IOVCC	V	
Output Signal Voltage	High Level	0.8 IOVCC	-		V	
	Low Level	-	-	0.2 IOVCC	V	
(Panel+LSI) Power Consumption	Black Mode	-	30	36	mW	
	Sleeping Mode	-	0.047	0.057	mW	

Table 4.1 LCD module electrical characteristics

4.2 Backlight Unit

Ta=25?

Item	Symbol	MIN	TYP	MAX	Unit	Remark
Forward Current	I_F	-	15	-	mA	One LED
Forward Voltage	V_F	(2.9)	3.2	(3.4)	V	One LED
Backlight Power Consumption	W_{BL}	-	192	-	mW	4 LEDs
Lifetime	T	-	20000	-	Hr	One LED

Table 4.2.1 backlight unit electrical characteristics

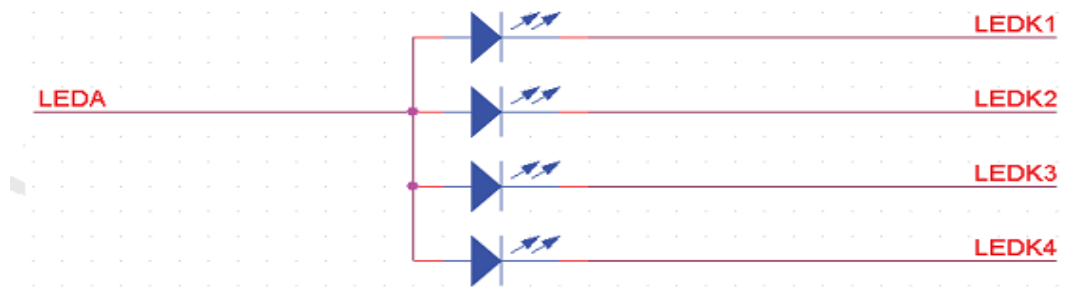
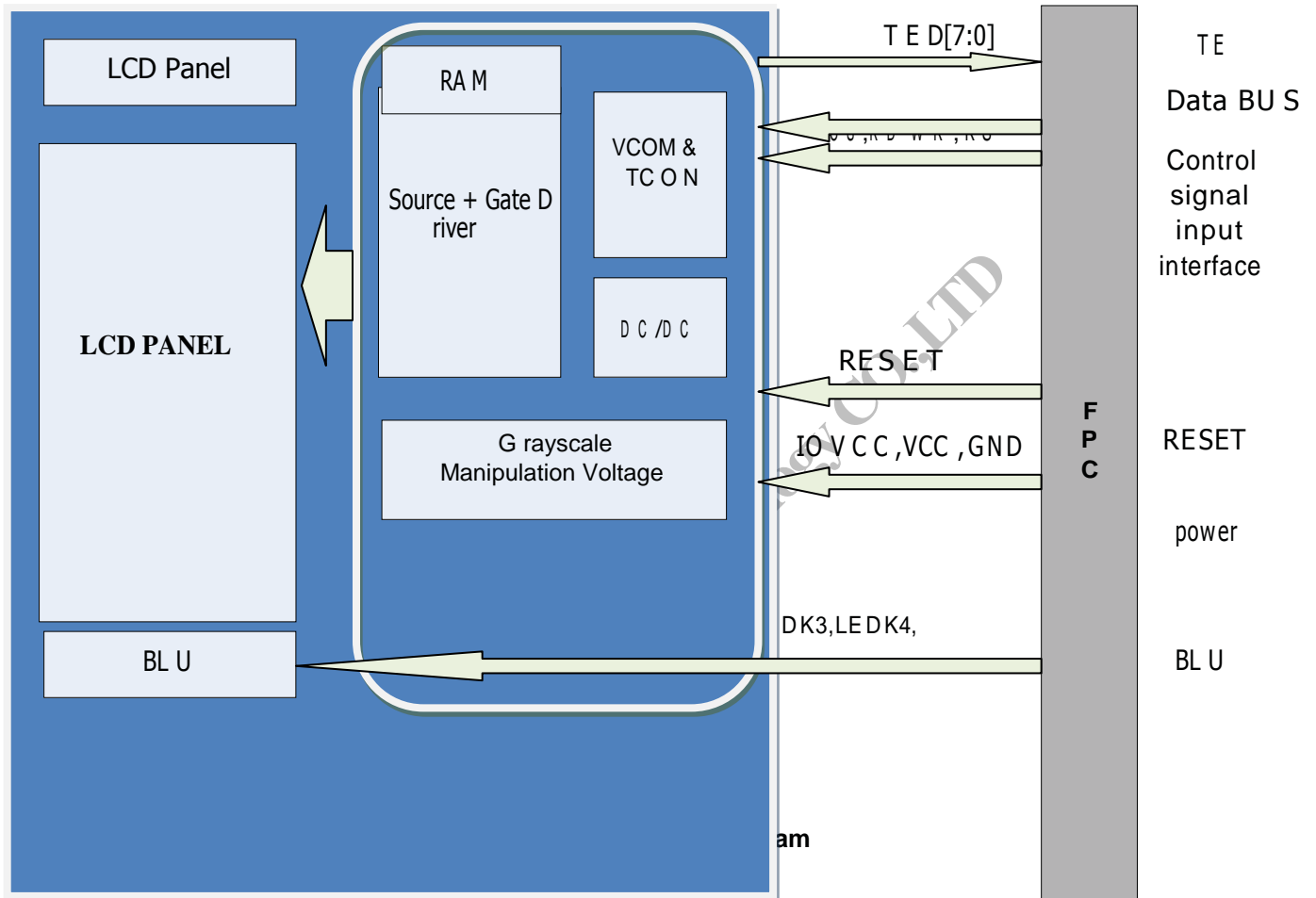

Figure 4.2.1 LED backlight circuit



4.3 Block Diagram





5 Timing Chart

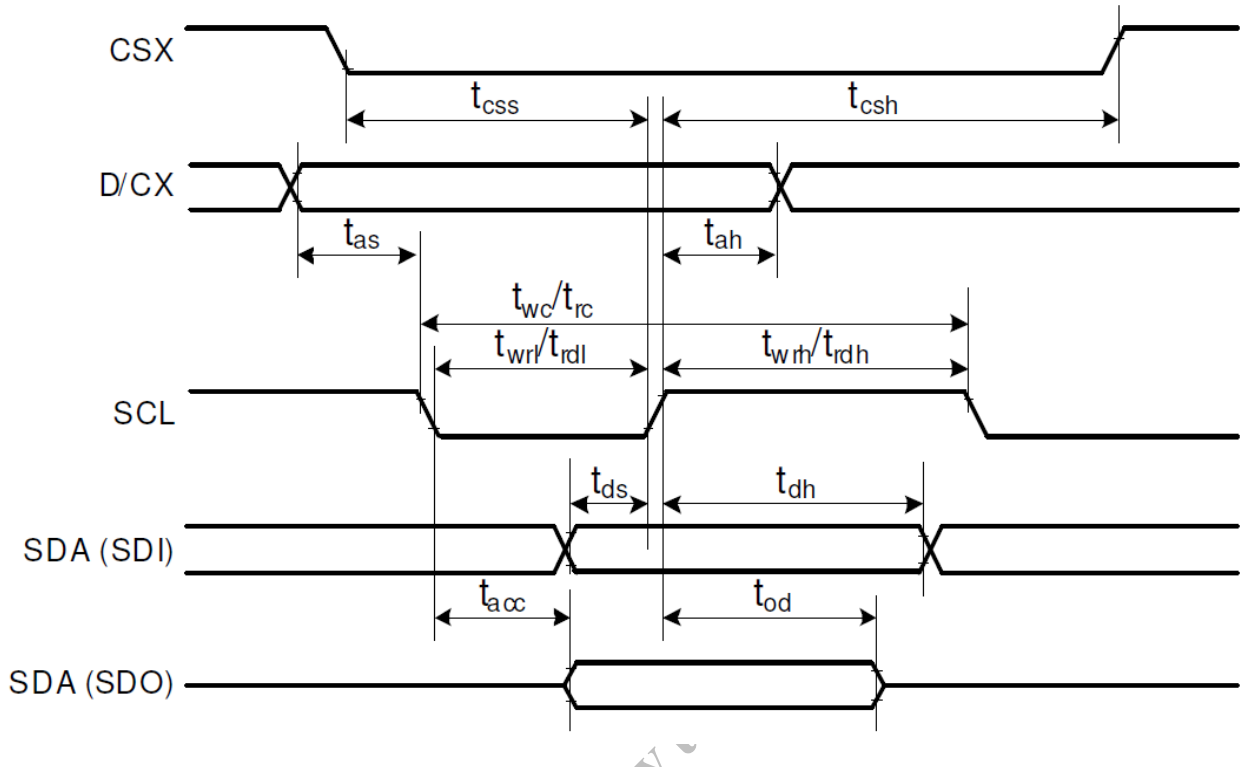

Signal	Symbol	Parameter	min	max	Unit	Description
CSX	tcss	Chip select time (Write)	40	-	ns	
	tcsh	Chip select hold time (Read)	40	-	ns	
SCL	twc	Serial clock cycle (Write)	100	-	ns	
	twrh	SCL "H" pulse width (Write)	40	-	ns	
	twrl	SCL "L" pulse width (Write)	40	-	ns	
	trc	Serial clock cycle (Read)	150	-	ns	
	trdh	SCL "H" pulse width (Read)	60	-	ns	
	trdl	SCL "L" pulse width (Read)	60	-	ns	
D/CX	tas	D/CX setup time	10	-		
	tah	D/CX hold time (Write / Read)	10	-		
SDA / SDI (Input)	tds	Data setup time (Write)	30	-	ns	
	tdh	Data hold time (Write)	30	-	ns	
SDA / SDO (Output)	tacc	Access time (Read)	10	-	ns	For maximum CL=30pF
	tod	Output disable time (Read)	10	50	ns	For minimum CL=8pF

Note: $T_a = -30$ to 70 °C, $V_{DDI}=1.65V$ to $3.3V$, $V_{CI}=2.5V$ to $3.3V$, $V_{SS}=0V$

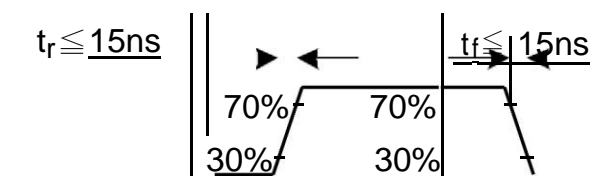

Table 5.1 timing parameter



5.2. Register write / read timing

a. Write to register

In 4-line serial interface, different display data format is available for two color depths supported by the LCM listed below.

-65k colors, RGB 5, 6, 5 -bits input.

-262k colors, RGB 6, 6, 6 -bits input.

16 bit/pixel color order (R:5-bit, G:6-bit, B:5-bit), 65,536 colors

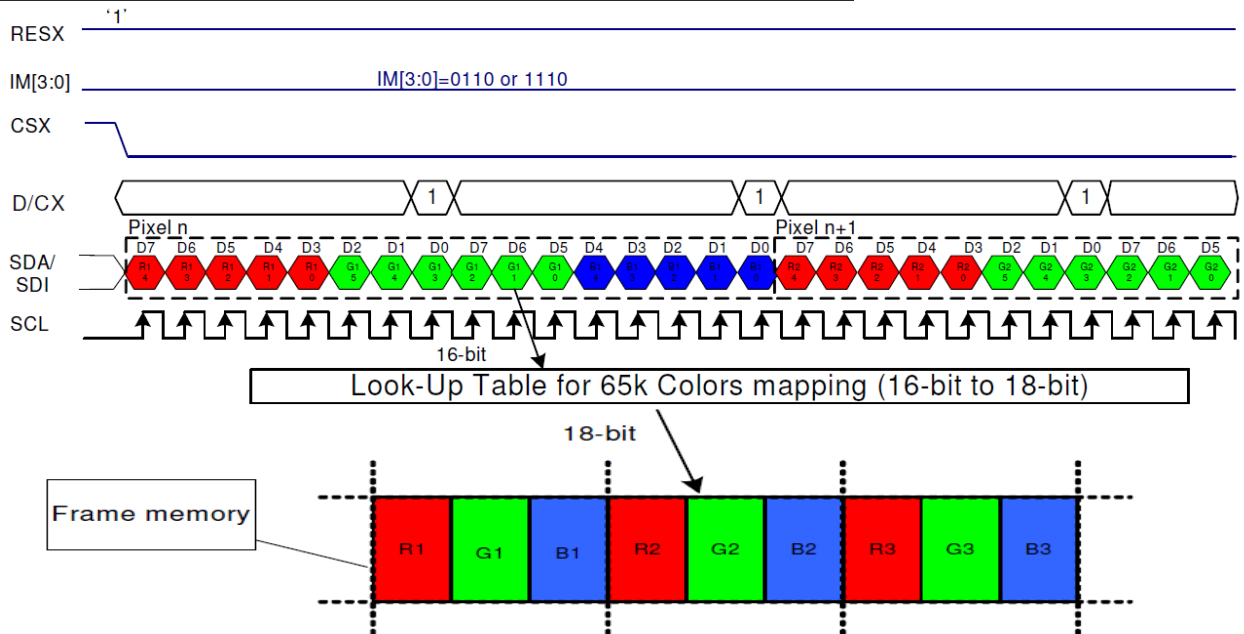



b. Read from register

Read data through 4-line SPI mode

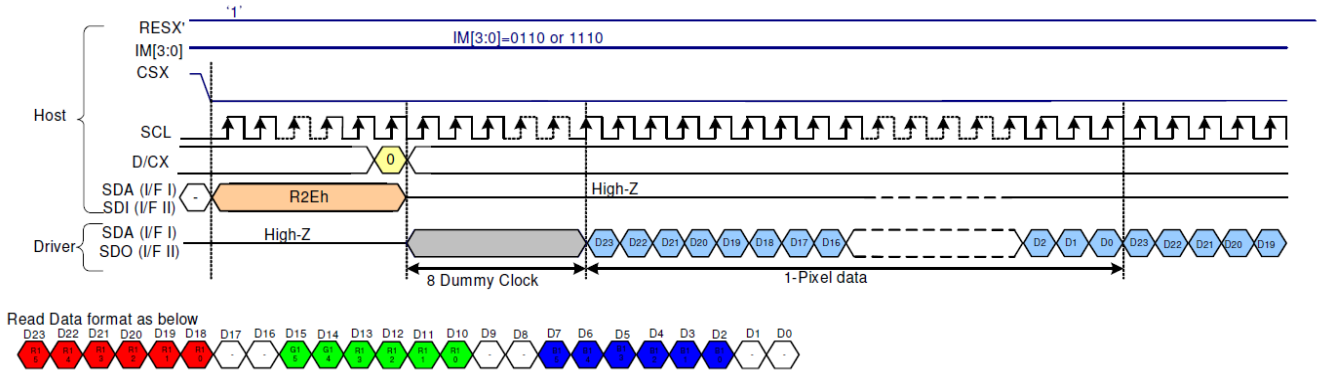

Note 1: '-'= Don't care – Can be set "0" or "1".

CS timings

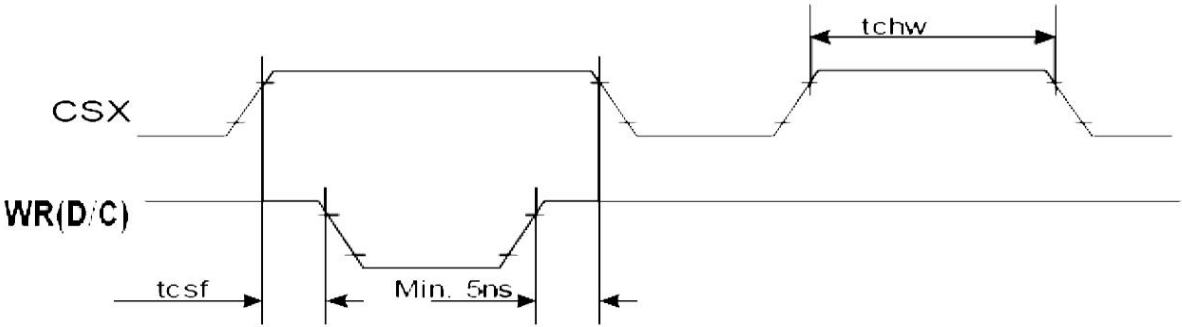

Figure 5.2.3 Chip selection timing



Write to read or read to write timings

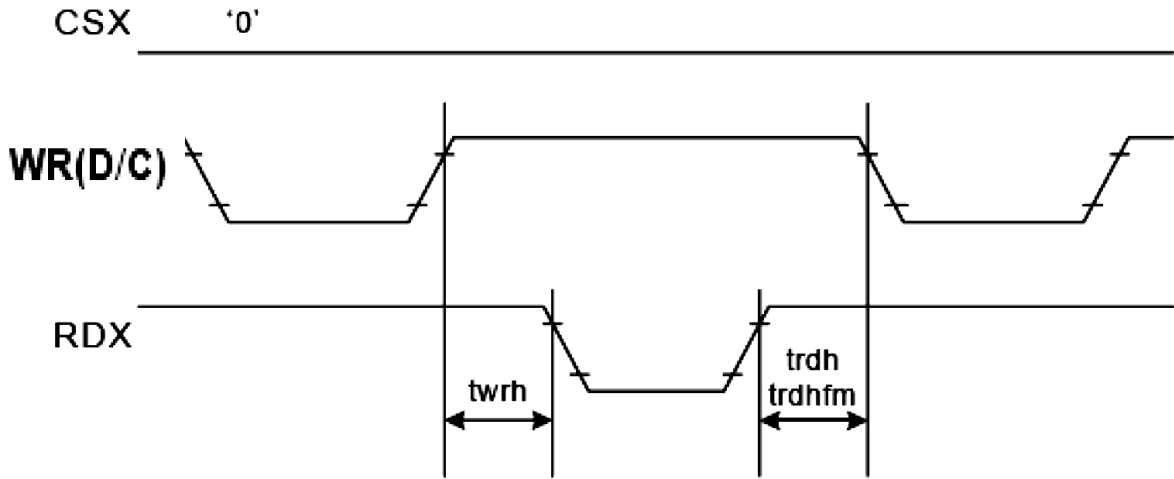
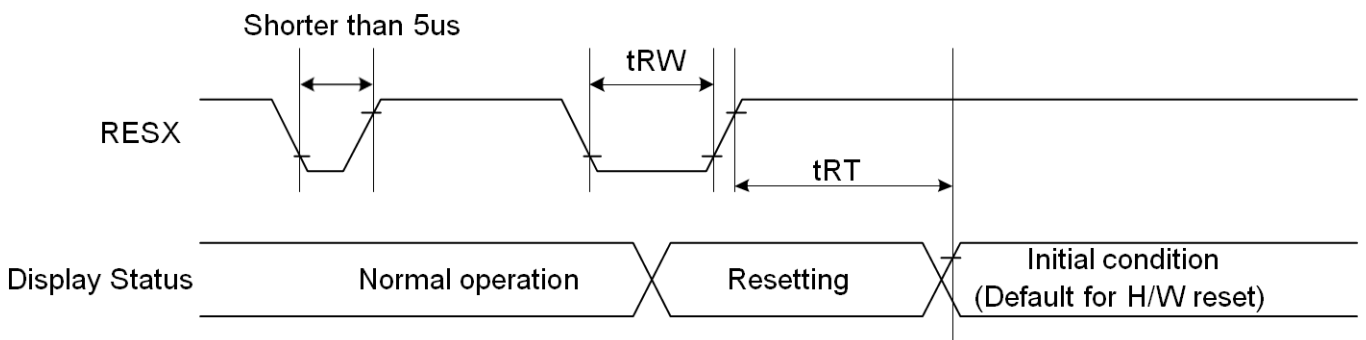

Figure 5.2.4 Write-to-read and read-to-write timing

5.3 Reset Timing Characteristics



Signal	Symbol	Parameter	Min	Max	Unit
RESX	tRW	Reset pulse duration	10		uS
	tRT	Reset cancel		5 (note 1,5)	mS
				120 (note 1,6,7)	mS

Figure 5.3 RESET Timing



5.4 Power on Sequence

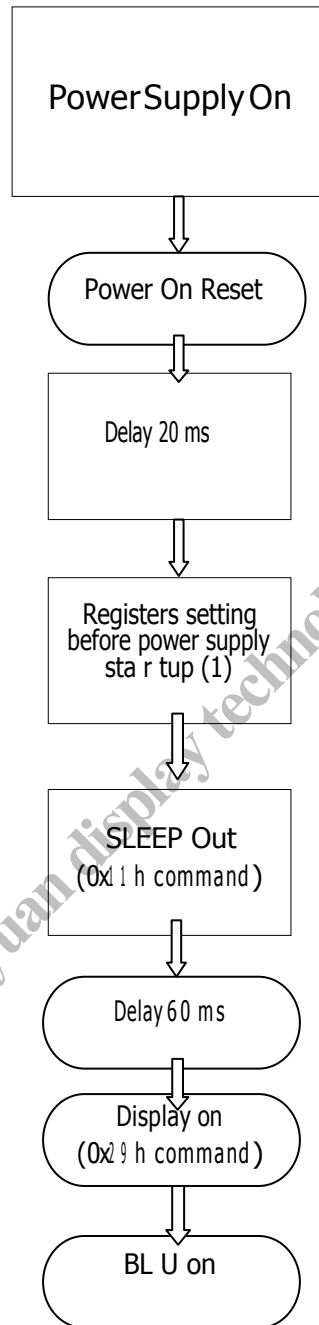



5.5 Power off Sequence

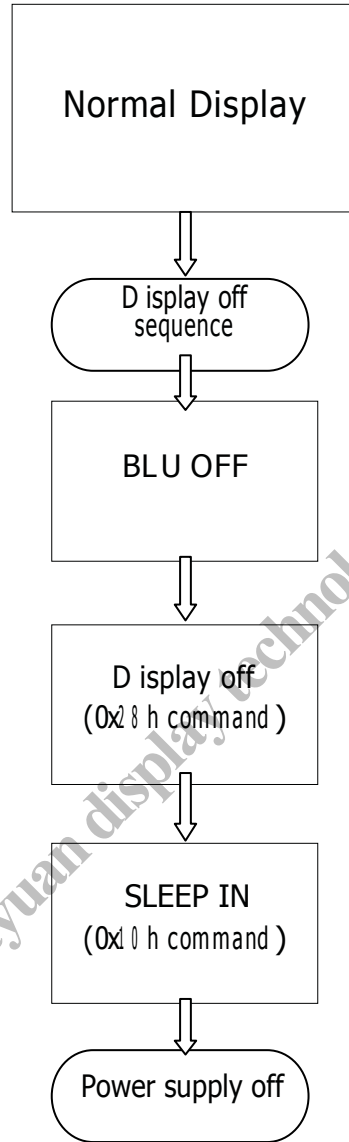



6. Optical Characteristics

Item	Symbol	Condition	Min	Typ	Max	Unit	Remark
View Angles	OT	CRŠ10	60	70	60	Degree	Note2,3
	OB		50	60	50		
	OL		60	70	60		
	OR		60	70	60		
Contrast Ratio	CR	0=0°	400	500	400		Note 3
Response Time	T _{ON}	25 °C		20	30	ms	Note 4
	T _{OFF}						
Chromaticity	White	Backlight is on	x	0.236	0.286	0.336	Note 1,5
			y	0.261	0.311	0.361	
	Red		x	0.530	0.580	0.630	Note 1,5
			y	0.270	0.320	0.370	
	Green		x	0.288	0.338	0.388	Note 1,5
			y	0.531	0.581	0.631	
	Blue		x	0.101	0.151	0.201	Note 1,5
			y	0.048	0.098	0.148	
Uniformity	U		-	80%		%	Note 6
NTSC			-	50%		%	Note 5
Luminance	L		180	200		cd/m ²	Note 7

Test Conditions:

1. I_F= 60mA, and the ambient temperature is 25°C.
2. The test systems refer to Note 1 and Note 2.



Note 1: Definition of optical measurement system.

The optical characteristics should be measured in dark room. After 5 Minutes operation, the optical properties are measured at the center point of the LCD screen. All input terminals LCD panel must be ground when measuring the center area of the panel.

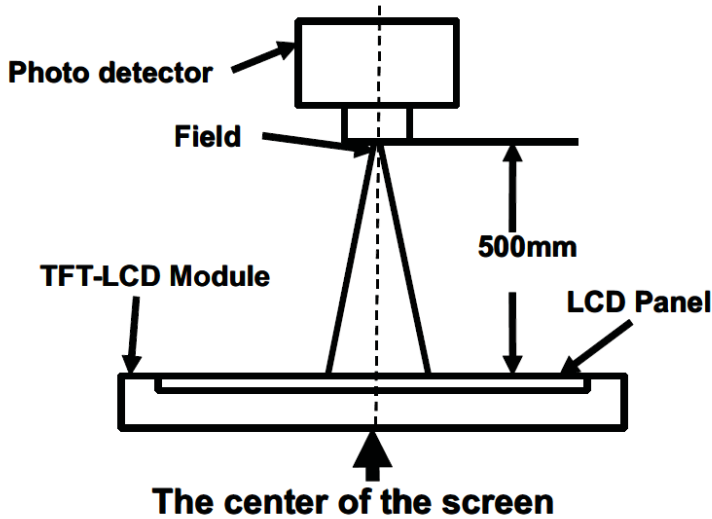

Item	Photo detector	Field
Contrast Ratio	SR-3A	1°
Luminance		
Chromaticity		
Lum Uniformity		
Response Time	BM-7A	2°

Note 2: Definition of viewing angle range and measurement system.

viewing angle is measured at the center point of the LCD by CONOSCOPE(ergo-80).

Note 3: Definition of contrast ratio

“White state “: The state is that the LCD should drive by Vwhite.

“Black state”: The state is that the LCD should drive by Vblack.



Vwhite: To be determined Vblack: To be determined.

Note 4: Definition of Response time

The response time is defined as the LCD optical switching time interval between “White” state and “Black” state. Rise time (T_{ON}) is the time between photo detector output intensity changed from 90% to 10%. And fall time (T_{OFF}) is the time between photo detector output intensity changed from 10% to 90%.

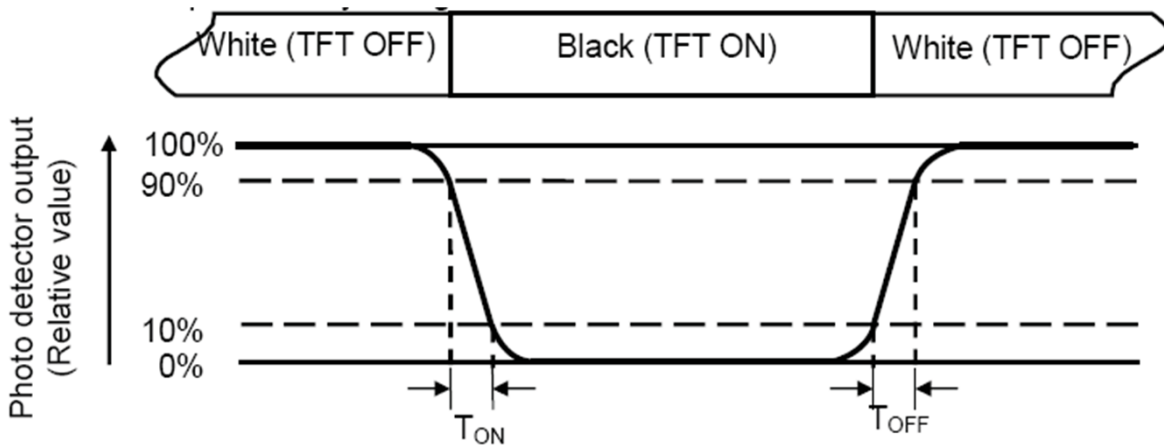

Note 5: Definition of color chromaticity (CIE1931)

Color coordinates measured at center point of LCD.

Note 6: Definition of Luminance Uniformity

Active area is divided into 9 measuring areas (Refer Fig. 2). Every measuring point is placed at the center of each measuring area.

$$\text{Luminance Uniformity (U)} = L_{\min} / L_{\max}$$

L-----Active area length W----- Active area width

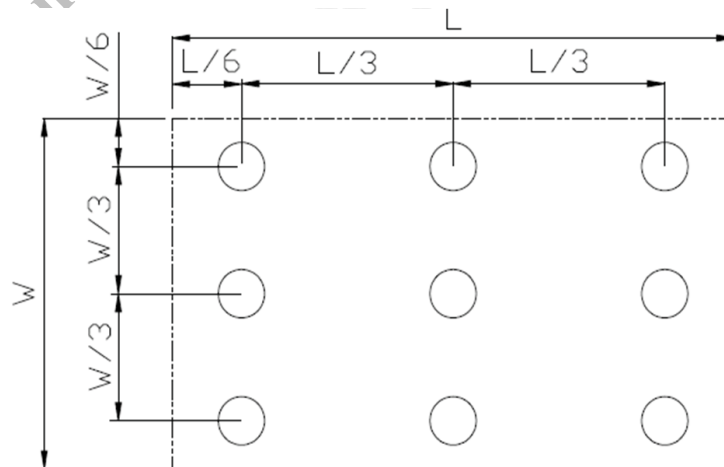

L_{\max} : The measured Maximum luminance of all measurement position.

L_{\min} : The measured Minimum luminance of all measurement position.

Note 7: Definition of Luminance:

Measure the luminance of white state at center point.



深圳市华源显控技术股份有限公司

Shenzhen HuaYuan display control technique.,Ltd

深圳市芯云显控技术有限公司

Shenzhen Chiloud display control Co.,Ltd

7 Environmental I Reliability Test

No	Test Item	Condition	Remarks
1	High Temperature Operation	Ts=+70°C 240hrs	IEC60068-2-1:2007 GB2423.2-2008
2	Low Temperature Operation	Ta=-20°C, 240hrs	IEC60068-2-1:2007 GB2423.1-2008
3	High Temperature Storage	Ta=+80°C, 240hrs	IEC60068-2-1:2007 GB2423.2-2008
4	Low Temperature Storage	Ta=-30°C, 240hrs	IEC60068-2-1:2007 GB2423.1-2008
5	Storage at High Temperature and Humidity	Ta=+60°C, 90% RH 240 hours	IEC60068-2-78 :2001 GB/T2423.3—2006
6	Thermal Shock (non-operation)	-30°C 30 min~+70°C 30 min, Change time:5min, 20 Cycles	Start with cold temperature, End with high temperature, IEC60068-2-14:1984,G B2423.22-2002
7	ESD	C=150pF, R=330K> 5points/panel Air:±8KV, 5times; Contact:±4KV, 5 times; (Environment: 15°C~35°C, 30%~60%, 86Kpa~106Kpa)	IEC61000-4-2:2001 GB/T17626.2-2006
8	Vibration Test	Frequency range:10~55Hz, Stroke:1.5mm Sweep:10Hz~55Hz~10Hz 2 hours for each direction of X.Y.Z. (6 hours for total)(Package condition)	IEC60068-2-6:1982 GB/T2423.10—1995
9	Mechanical Shock (Non OP)	60G 6ms, ±X,±Y,±Z 3times, for each direction	IEC60068-2-27:1987 GB/T2423.5—1995
10	Package Drop Test	Height:80 cm, 1 corner, 3 edges, 6 surfaces	IEC60068-2-32:1990 GB/T2423.8—1995

Note1: Ts is the temperature of panel's surface.

Note2: Ta is the ambient temperature of sample.

Note3: Before cosmetic and function test, the product must have enough recovery time, at least 2 hours at room temperature.

Note 4: In the standard condition, there shall be no practical problem that may affect the display function. After the reliability test, the product only guarantees operation, but don't guarantee all of the cosmetic specification.

确认此型号所有图纸，签字确认：

次数	变更号	修改内容	日期	执行人
1	--		2018-11-02	

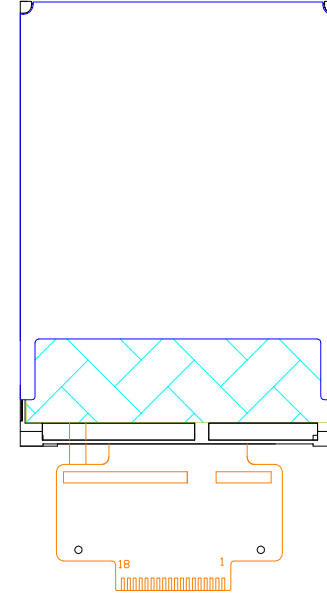
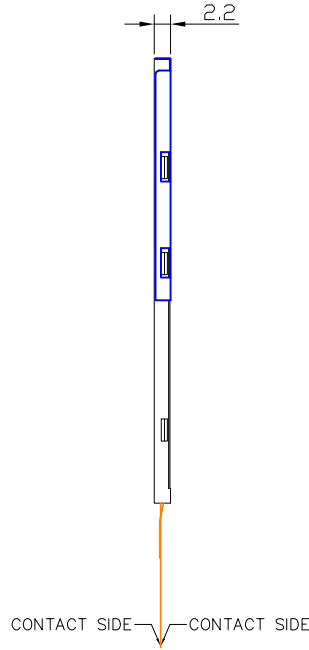
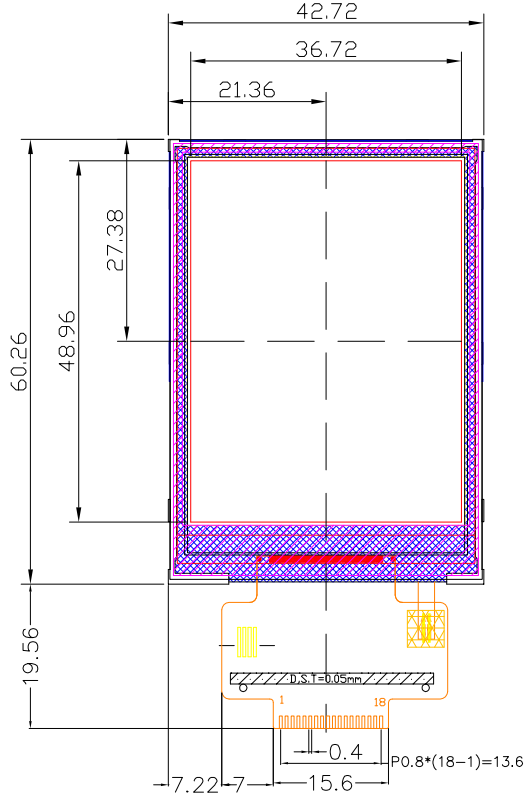

1	VSS
2	RESET
3	SCL
4	RS
5	/CS
6	SDA
7	SDO
8	VSS
9	VCC
10	LEDA
11	LEDK1
12	LEDK2
13	LEDK3
14	LEDK4
15	XL(NC)
16	YU(NC)
17	XR(NC)
18	YD(NC)

NOTES:

- DISPLAY TYPE: 2.4" 65K TFT, TRANSMISSIVE
- LCM OPERATING VOLTAGE: 3.3V
- OPERATING TEMPERATURE: -10°C TO +60°C
- STORAGE TEMPERATURE: -20°C TO +70°C
- DRIVE IC: ILI9341
- BACK LIGHT TYPE: VF=3.0V, IF=90mA
- UNMARKED TOLERANCE is ±0.2mm

BACK LIGHT CIRCUIT DIAGRAM

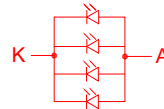

深圳市华源显控技术股份有限公司
Shenzhen HuaYuan display control technology Co., Ltd
深圳市芯云显控技术有限公司
Shenzhen Chiloud display control Co., Ltd

DESIGNED BY:		VERSION: 1.0
CHECKED BY:		NO.: 1 OF 1
APPROVED BY:		UNIT: mm
CONFIRMED BY:		DATE: 2018/11/02



9 Precautions for Use of LCD Modules

8.1 Handling Precautions

8.1.1 The display panel is made of glass. Do not subject it to a mechanical shock by dropping it from a high place, etc.

8.1.2 If the display panel is damaged and the liquid crystal substance inside it leaks out, be sure not to get any in your mouth, if the substance comes into contact with your skin or clothes, promptly wash it off using soap and water.

8.1.3 Do not apply excessive force to the display surface or the adjoining areas since this may cause the color tone to vary.

8.1.4 The polarizer covering the display surface of the LCD module is soft and easily scratched. Handle this polarizer carefully.

8.1.5 If the display surface is contaminated, breathe on the surface and gently wipe it with a soft dry cloth. If still not completely clear, moisten cloth with one of the following solvents:

- Isopropyl alcohol
- Ethyl alcohol

Solvents other than those mentioned above may damage the polarizer. Especially, do not use the following:

- Water
- Ketone
- Aromatic solvents

8.1.6 Do not attempt to disassemble the LCD Module.

8.1.7 If the logic circuit power is off, do not apply the input signals.

8.1.8 To prevent destruction of the elements by static electricity, be careful to maintain an optimum work environment.

8.1.8.1 Be sure to ground the body when handling the LCD Modules.

8.1.8.2 Tools required for assembly, such as soldering irons, must be properly ground.

8.1.8.3 To reduce the amount of static electricity generated, do not conduct assembly and other work under dry conditions.

8.1.8.4 The LCD Module is coated with a film to protect the display surface. Be care when peeling off this protective film since static electricity may be generated.

8.2 Storage precautions

8.2.1 When storing the LCD modules, avoid exposure to direct sunlight or to the light of fluorescent lamps.

8.2.2 The LCD modules should be stored under the storage temperature range. If the LCD modules will be stored for a long time, the recommend condition is:

Temperature : 0? ~ 40? Relatively humidity: “80%

8.2.3 The LCD modules should be stored in the room without acid, alkali and harmful gas.

8.3 Transportation Precautions

The LCD modules should be no falling and violent shocking during transportation, and also should avoid excessive press, water, damp and sunshine.