



Hunan Huayuan display technology CO.,LTD

GH240160-4001

STN DOTS LCD MODULE

SPECIFICATION

Standard code	Department	Rev No.
BYD15166A	R&D	A/0
Checked by	Written by	Date
		2015-07

1. **GENERAL SPECIFICATIONS**
2. **ELECTRICAL CHARACTERISTICS**
3. **ABSOLUTE MAXIMUM RATINGS**
4. **OPTICAL CHARACTERISTICS**
5. **EXTERNAL DIMENSIONS**
6. **INTERAFACE DESCRIPTION**
7. **RELIABILITY TEST**
8. **LIQUID CRYSTAL MODULE USE MATTERS NEEDING ATTENTION**

1、 GENERAL SPECIFICATIONS

Screen size	4.0"(Diagonal)
Display color	Display color: White Background color: Blue
Type	STN
Viewing angle	6'clock
Driver mode	1/160 DUTY 1/12 BIAS
Backlight	LED/White
Controller IC	UC1611S
Data Bus	SPI
Temperature range	Operation: -20 °C ---- +70°C Storage: -30 °C ---- +80°C
Number of Dots	240 x 160
Dot size	0.32 x 0.32mm
Dot pitch	0.34 x 0.34mm
Viewing size	85.6 x 58.4mm
Active area	81.58 x 54.38mm
Outline dimension	100.00 x 89.00 x 9.60mm Max.

2、 ELECTRICAL CHARACTERISTICS

Parameter	Symbol	Min	Type	Max	Unit
Supply voltage for logic	$V_{DD}-V_{SS}$	4.75	5.0	5.25	V
Supply Voltage for LCD Driving	V_O-V_{DD}	Ta=0 °C	-	-	
		Ta=25 °C	-	16.5	
		Ta=50 °C	-	-	
Input Voltage	V_{IH}	0.8 V_{DD}	-	$V_{DD} + 0.3$	
	V_{IL}	0	-	0.2 V_{DD}	
Supply Voltage for LED	V_{LED}	-	5.0	5.25	mA
Supply Current for LCM	I_{DD}	-	-	15	
Supply Current for LCD Driving	I_{EE}	0.0	-	2.0	
Supply Current for LED	I_{LED}	-	-	120	

3、 ABSOLUTE MAXIMUM RATINGS

Parameter	Symbol	Min	Max	Unit	Remark
Supply voltage for logic	$V_{DD}-V_{SS}$	-0.3	+7.0	V	
Supply Voltage for LCD Driving	$V_{ADJ}-V_{SS}$	-	20.0		
Operating temperature	T_{OP}	-20	+70	°C	
Storage temperature	T_{ST}	-30	+80		

4、 OPTICAL CHARACTERISTICS

Item	Symbol	Condition	Typ.	Unit	Remark	
Viewing angle	$\varnothing f$	$C_R \geq 2$	40	Radian	$\varnothing f$	
	$\varnothing b$		30		$\varnothing b$	
	$\varnothing l$		30		$\varnothing l$	
	$\varnothing r$		30		$\varnothing r$	
Response time	T_R	TA=25 °C	120	ms		
	T_F		130			
Frame Frequency	F_{RM}			64	Hz	
Contrast ratio	C_R			6.0	-	

5、 EXTERNAL DIMENSIONS

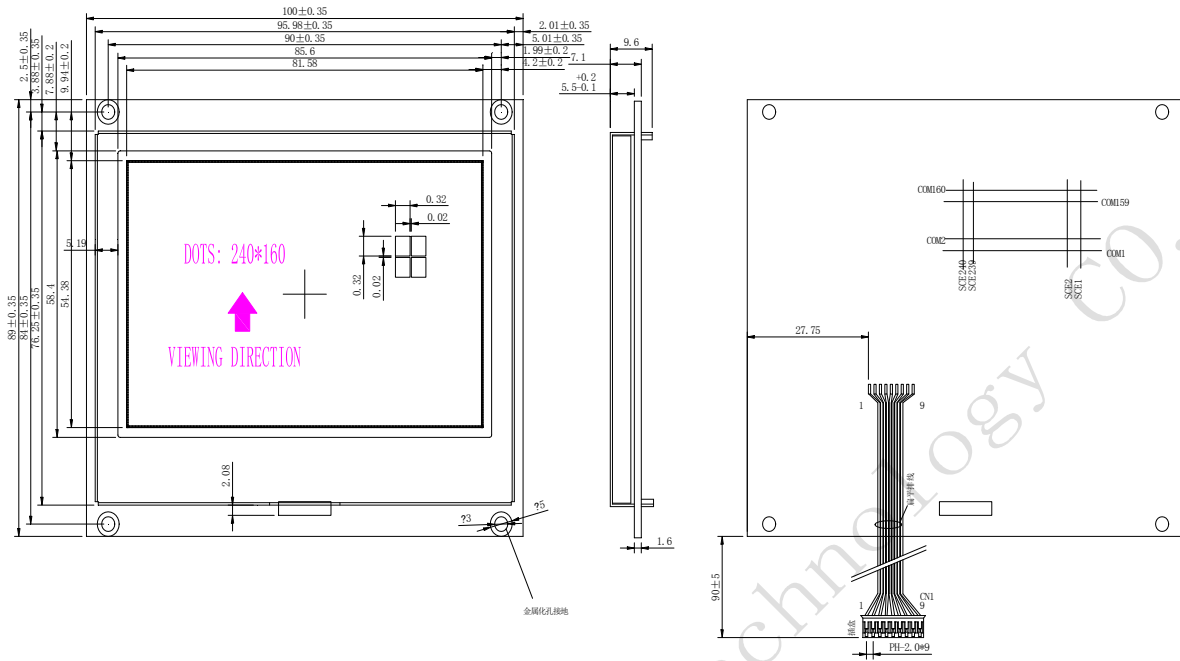

6、 INTERFACE DESCRIPTION

PIN	DESC	Function
1	CS0	Chip Select 0: Active low
2	RST	Reset Signal: Active low
3	A0	Command/Data Select.
4	SCLK	The serial clock input
5	SDA	Serial data input
6	VDD	Power supply for Logic circuit and LCD
7	VSS	Ground
8	LEDK	K
9	LEDA	A

7、 RELIABILITY TEST

NO	Test Project	Test Condition	Remark
1	High temperature	60°C ± 2°C 24H	After testing, the appearance and electrical
2	Low temperature	-20°C ± 2°C 24H	
3	High temperature and humidity test	40°C ± 5°C × 90%RH/24H	
4	Hot and cool shock	-10°C ± 2 → 25°C → 70°C ± 2	

	test	(30min) (5min) (30min) 10 cycles	performance deficiencies should not happen.
5	Vibration test	10Hz-50Hz-10Hz Amplitude 1.5mm X、Y、Z each 3H	

Remark:

1. Above test number is 2 piece.
2. Do moistureproof test, should use the pure water (10M Ω resistor ").
3. individual products caused by electrostatic discharge failure damage, if the products will be reset after the restore to the normal state as a good use.
- When the panel protective film LCM, Tear down the labels slowly (more than a second recommendation).
- 4 Please use the automatic switching menu (or scroll) test mode, test mode of operation.
- 5 Suggestions Use the menu to adjust the contrast model.

8、 LIQUID CRYSTAL MODULE USE MATTERS NEEDING ATTENTION

1. When using the liquid crystal module you design your product, pay attention to the liquid crystal perspective and uses your consistent.
2. The LCD screen is the glass based, dropping or with a hard object impact will cause cracking or crushing the LCD screen. Especially in the corner.
3. In spite of the polarizer, liquid crystal surface can inhibit the reflective surface, should be careful not to scratch the surface, generally recommend using the protective screen of transparent plastic material in the liquid crystal surface.
4. If the LCD module storage in the following below the required temperature, liquid crystal material condenses and performance deterioration. If the LCD module storage above the specified temperature, molecular crystal orientation will be transformed into liquid, may not be restored to the original state. Beyond the temperature and humidity range, will cause the polarizer peeling or foaming. Therefore, the LCD module should be stored at the specified temperature range.
5. Such as liquid crystal surface in slobber or drop, should immediately erase, avoid long time after induced color changes or leave a stain. The water vapor will cause erosion of ITO electrode
6. If you need to clean the surface of the LCD screen, should use cotton or soft cloth lightly wipe, is still not clear, smooth and then wipe.
7. LCD module driver shall comply with the provisions of the rating index, and avoid the fault and permanent damage. DC voltage applied to the liquid crystal materials, liquid crystal materials will cause rapid deterioration, should ensure the continuous application of M signal to provide AC waveform. Especially, when a power switch shall comply with the order of power supply, avoid driving

latch and DC added directly to the LCD screen.

8. Machine Matters needing attention

- a) The LCD module is arranged on the high precision of the debugging. To avoid the impact of external force, do not modify or change
- b) Do not tamper with Any prominent part of the metal frame
- c) Don't punch a hole in PCB or change in shape, do not move or modify elements.
- d) Don't touch the conductive rubber, especially in the insert backlight board. (such as EL backlight).
- e) In the installation of the LCD module, ensure that the PCB was not affected by the twisting or bending force force. Conductive rubber contact is very precise, dislocation slightly in the original basis will lead to the missing pixels.
- f) To avoid pressure on the metal clamping part, otherwise it will lead to the conductive rubber deformation and lost contact, causing the missing pixels.

9. Static electricity: Because the liquid crystal module internal assembly CMOS circuit, must take the following measures to prevent electrostatic

a) The operator

1. Wear anti-static clothing, otherwise the body will produce static electricity.
2. Any part of the body of the time should not be exposed conductive parts and modules, such as: integrated circuit pin, copper wire PCB, terminal interface part.

b) Equipment

1. The detachment or friction may cause the equipment to generate static electricity, such as personnel, iron, table etc.
2. the equipment connected to the appropriate resistance (1x10⁸ ohm).
3. Just only Reasonable grounding soldering iron can use
4. If the use of electric screwdriver, electric batch should be well grounded and adapter (brush) isolation
5. normally Should be observed overalls, anti static measurement work benches, for work bench, recommend the use of conductive rubber pad

c) Floor

1. The floor is the electrostatic equipment and personnel are an important part of the release. May be due to electrostatic floor insulation cannot release. Set the floor to ground (1x10⁸ Ohm)

d) Humidity

1. Probability of proper humidity can reduce static electricity. General relative humidity should be maintained at more than 50%.

e) Transportation and storage

1. Because people and packaging materials may be separated or friction caused by static electricity, packaging materials need antistatic treatment. Module should be stored in anti-static bag or other ESD container.

f) Welding

1. Welding of I/O terminal only. Use only the reasonable grounding and no leakage of iron. Low temperature tin wire filled with solder paste.
2. If the use of flux, should cover the liquid crystal surface, prevent solder spatter. After the removal of flux residues.
3. The welding temperature: 280 ° C+10 ° C

4. Welding time: 3-4 seconds.
- g) Other: with the protective film attached to the surface of the liquid crystal screen and to prevent scratches on the surface or pollution, in stripping the protective film, should use the static eliminator. Static eliminator should also be installed in the table, from static to prevent
10. operating
 - 1). The drive voltage should be controlled within a specified range, beyond the range will shorten the service life of the liquid crystal
 - 2). Liquid crystal response time will increase with the decrease of temperature
 - 3). When the temperature is higher than the operating temperature range, the liquid crystal display will turn black or dark blue, which may lead to "break" column. No matter what, do not squeeze the display area
 - 4) Mechanical disturbance during operation (such as in the display region extrusion) may lead to "break" column
 11. If the outflow of liquid glass layer damaged, wash thoroughly with soap and water come into contact with the body, although very low toxicity, still need to remind the attention
 12. Dismantling the LCD module can cause permanent damage, should be strictly prohibited
 13. Liquid crystal with image retention afterglow, in order to avoid image afterglow don't long time display fixed pattern. Image persistence is not liquid crystal deterioration, when the display pattern changes will automatically eliminate
 14. Do not use a volatile epoxy resin and silicone adhesives, to prevent the resulting Polaroid color
 15. To avoid the liquid crystal module long time exposure to sunlight or ultraviolet irradiation
 16. Brightness of the LCD module may be due to the coupling of shunt CCFL lead to the metal shell of the affected. Inverter design should take full account of this part of the leakage. It is necessary to fully assess the LCD module and the inverter is installed in the host apparatus, ensure the requirement of brightness

a. Working driving voltage is defined (Vop)

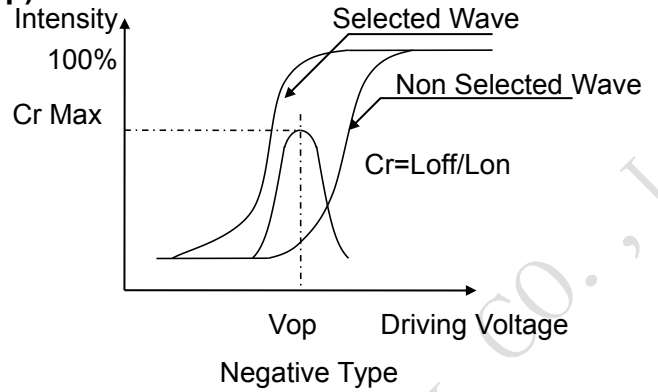
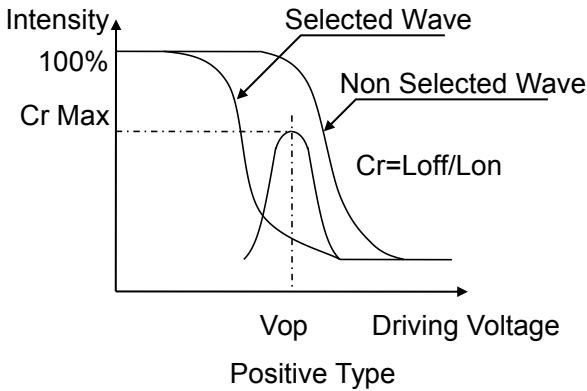

b. The liquid crystal response time is defined (Tr, Tf)

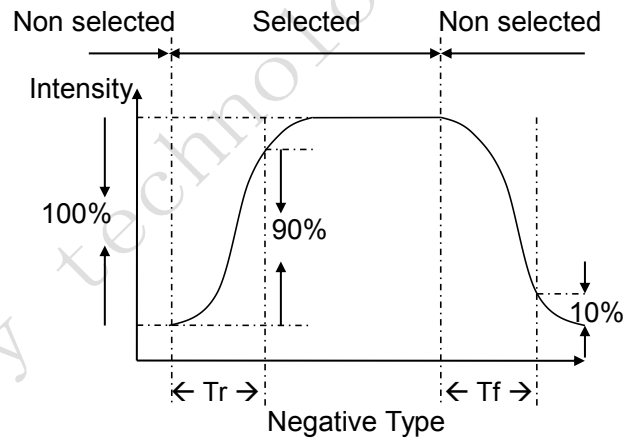
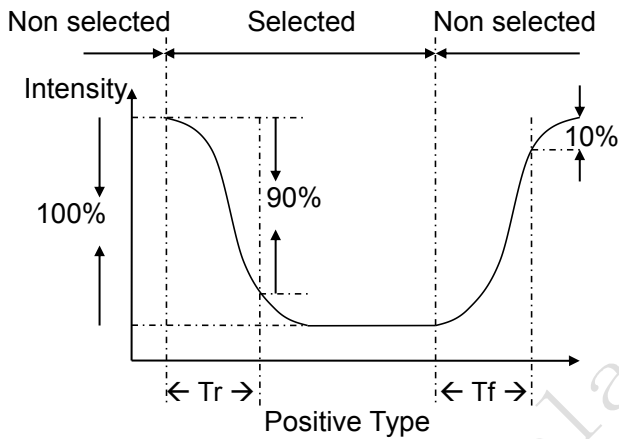

Conditions:

Operating Voltage : Vop
Frame Frequency : 64 Hz

Viewing Angle: 0°

Driving Wave form : 1/N duty, 1/a bias

c. Definition Viewing Angle

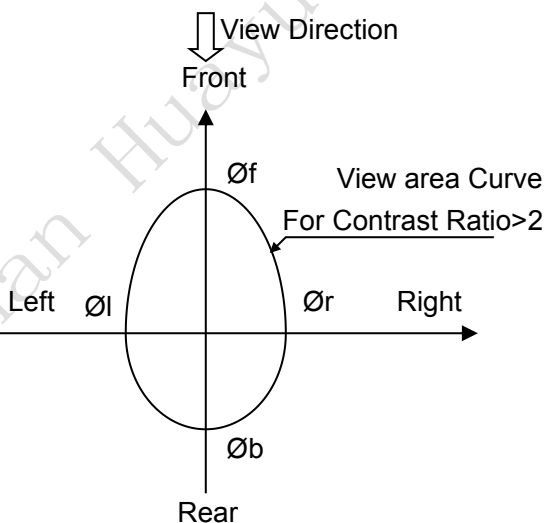

Item	Symbol	Condition	Type	Unit
View Angle Range	Øf	Contrast>2	40	Degree
	Øb		30	
	Øl		30	
	Ør		30	

d. Perspective Definition

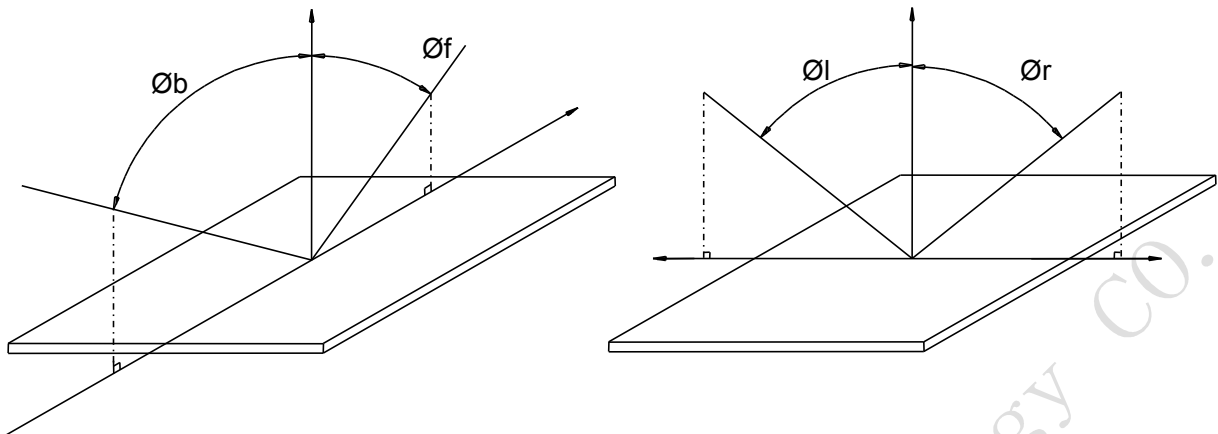

e. Measurement Method Described

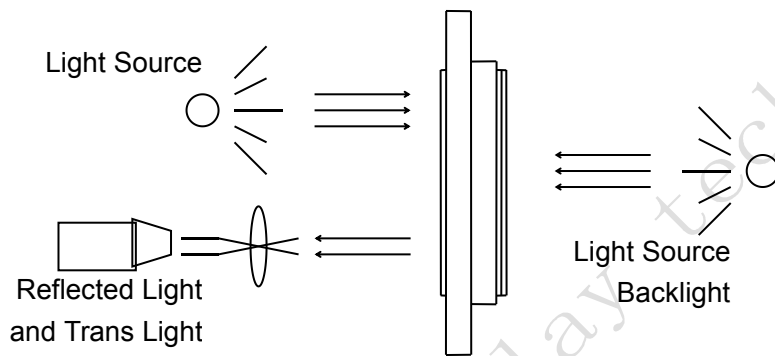

TransFlective Type

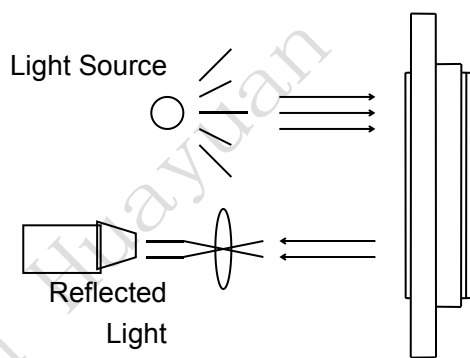

ReFlective Type